



**BALTIMORE
AIRCOIL COMPANY**



TSU-M ICE CHILLER® Thermal Storage Unit for internal melt

RIGGING AND INSTALLATION INSTRUCTIONS





About rigging and installation

The BAC equipment should be rigged and installed as outlined in this bulletin.

These procedures should be thoroughly reviewed prior to the rigging and operation to acquaint all personnel with the procedures to be followed and to assure that all necessary equipment will be available at the job site.

Recommended maintenance and monitoring programme

Checks and adjustments	Start-Up	Monthly	Quarterly	Every 6 months	Annually	Shutdown
Operating level	X	X				
System charging	X					

Inspections and monitoring	Start-Up	Monthly	Quarterly	Every 6 months	Annually	Shutdown
General condition	X	X				
Ice Chiller® tank	X		X			
Ice Chiller® water ⁽¹⁾						
- Quality	X			X		
- Level	X	X				
Ice thickness	X	X				
Coil	X			X		
Ice Logic™ Ice Quantity controller:						
- condition of sensor	X	X				
Refrigerant:						
- Glycol quality				X		

Cleaning procedures	Start-Up	Monthly	Quarterly	Every 6 months	Annually	Shutdown
Disinfection	X				X	X

Notes

1. Water treatment and auxiliary equipment integrated in the cooling system may require additions to the table above. Contact suppliers for recommended actions and their required frequency.
2. Recommended service intervals are for typical installations. Different environmental conditions may dictate more frequent servicing.
3. When operating in ambient temperatures below freezing, the installation should be inspected more frequently.

Table of contents

RIGGING AND INSTALLATION INSTRUCTIONS



1	General information	4
	About engineering and application practices	4
	Shipping	4
	Inspection Before Rigging	4
	Unit weights	5
	Leveling	5
	Connecting pipework	5
	Coil connections	6
	Freeze protection	6
	Safety precautions	6
	Non-walking surfaces	7
	Modifications by others	7
	Warranty	8
2	Rigging	9
	General notes	9
	Support requirements	9
	Recommended rigging method for 3,2 m long units	10
	Recommended rigging method for 6 m long units	11
	System charging	11
	Purge requirements	12
3	Inspection prior to start-up	13
	General	13
4	Further Assistance & Information	14
	Assistance	14
	More information	14

About engineering and application practices

This bulletin only refers to the assembly of the unit. To ensure a proper operation, a correct integration of the unit in the overall installation is mandatory. For good engineering and application practices on layout, levelling, connecting pipework, etc., please refer to our website: <http://www.baltimoreaircoil.eu/knowledge-center/application-information>.

Shipping

BAC equipment is factory assembled to assure uniform quality and minimum field assembly. For the dimensions and weights of a specific unit or section, refer to the certified drawing. Before final placement of the thermal storage unit, remove the shipping skids, as illustrated in below figures.



Removal of shipping skids – Side view & End view

Remove these screws to unfasten shipping skid. Re-install screws where necessary.

Inspection Before Rigging

When the unit is delivered to the jobsite, it should be checked thoroughly to ensure all required items have been received and are free of any shipping damage prior to signing the bill of lading.

The following parts should be inspected:

- Exterior panels and covers
- Ice coils
- Sight tube and Ice Logic ice quantity controller (optional)

If shipping damage has occurred, this should be clearly indicated on the CMR.

Unit weights

Before rigging any BAC equipment, the weight of each section should be verified on the unit certified drawing. Refer to the Rigging section for weight values.

 These weights are **approximate** only and should be confirmed by weighing **before lifting** when available hoisting capacity provides little margin for safety.

Model - TSU-M	Approx. shipping weight (kg)
TSU-237M	4420
TSU-476M	7590
TSU-594M	9150
TSU-761M	10990
TSU-L184M	3760
TSU-L370M	6400
TSU-L462M	7710
TSU-L592M	9200

Approximate shipping weights TSU-M



CAUTION

Before an actual lift is undertaken, ensure no water, snow, ice or debris has collected in the unit. Such accumulations will add substantially to the equipment's lifting weight.

Leveling

The unit must be level for proper operation and ease of piping.

The unit **MUST** be installed on a concrete slab with a levelness or maximum slope of 2 mm per meter and the flatness should be no more than 6 mm over a 3 meter span.

Support beams must also be level as shims should not be used between pan and support beams to level the unit.

Connecting pipework

All piping external to BAC cooling equipment must be supported separately.

In case the equipment is installed on vibration rails or springs, the piping must contain compensators to eliminate vibrations carried through the external pipework.

All connections in the external pipework (installed by others) must be leak free and tested accordingly.

Coil connections

Coils of BAC ice thermal storage units are filled with a low pressure inert gas at the factory before shipping, to ensure an optimal internal corrosion protection. It is recommended to check the overpressure every six months (connect a manometer to the valve).

On site, the pressure needs to be released from the coil. Remove the plug first before opening the pressure relieve valve.

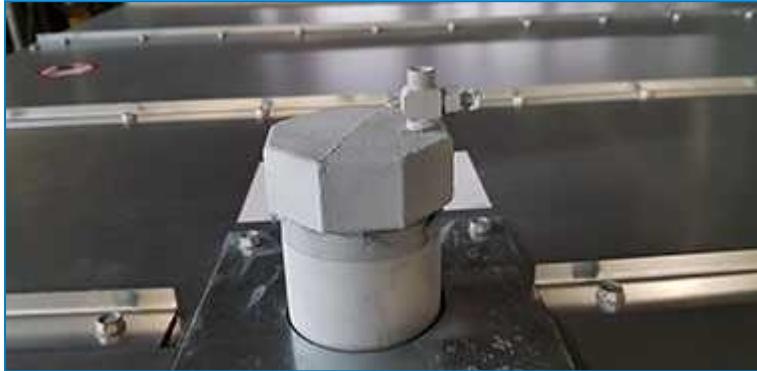

Threaded coil connection on ice thermal storage



CAUTION

Once the coil is no longer protected by the inert gas, proper actions against corrosion must be taken on site.

Freeze protection

These products must be protected against damage and/or reduced effectiveness due to possible freeze-up by mechanical and operational methods. Please contact your local BAC representative for recommended protection alternatives.

Safety precautions

All electrical, mechanical and rotating machinery constitutes a potential hazard, particularly for those not familiar with its design, construction and operation. Accordingly, adequate safeguards (including use of protective enclosures where necessary) should be taken with this equipment both to safeguard the public (including minors) from injury and to prevent damage to the equipment, its associated system and the premises. If there is doubt about safe and proper rigging, installation, operation or maintenance procedures, contact the equipment manufacturer or his representative for advice.

When working on operating equipment, be aware that some parts may have an elevated temperature. Any operations on elevated level have to be executed with extra care to prevent accidents.

AUTHORIZED PERSONNEL

The operation, maintenance and repair of this equipment should be undertaken only by personnel authorized and qualified to do so. All such personnel should be thoroughly familiar with the equipment, the associated systems and controls and the procedures set forth in this and other relevant manuals. Proper care, personal protective equipment, procedures and tools must be used in handling, lifting, installing, operating, maintaining and repairing this equipment to prevent personal injury and/or property damage. Personnel must use personal protective equipment where necessary (gloves, ear plugs, etc...)

MECHANICAL SAFETY

Mechanical safety of the equipment is in accordance with the requirements of the EU machinery directive. Depending upon site conditions it also may be necessary to install items such as bottom screens, ladders, safety cages, stairways, access platforms, handrails and toe boards for the safety and convenience of the authorized service and maintenance personnel.

At no time this equipment should be operated without all access cover panels and access doors in place/closed and properly secured.

For more information consult your local BAC representative.

LIFTING



CAUTION

Failure to use designated lifting points can result in a dropped load causing severe injury, death and/or property damage. Lifts must be performed by qualified riggers following BAC published Rigging Instructions and generally accepted lifting practices. The use of supplemental safety slings may also be required if the lift circumstances warrant its use, as determined by the rigging contractor.

LOCAL REGULATIONS

Installation and operation of cooling equipment may be subject to local regulations, such as establishment of risk analysis. Ensure regulatory requirements are consistently met.

Non-walking surfaces

Access to and maintenance of any component needs to be performed in accordance with all local applicable laws and regulations. If the proper and required access means are not present, temporary structures need to be foreseen. Under no circumstance can one use parts of the unit, that are not designed as an access mean, unless measures can be taken to mitigate any risks that might occur from doing so.

Modifications by others

Whenever modifications or changes are made by others to the BAC equipment without written permission of BAC, the party who has done the modification becomes responsible for all consequences of this change and BAC declines all liability for the product.



Warranty

BAC will guarantee all products to be free from manufactured defects in materials and workmanship for a period of 24 months from the date of shipment. In the event of any such defect, BAC will repair or provide a replacement. For more details, please refer to the Limitation of Warranties applicable to and in effect at the time of the sale/purchase of these products. You can find these terms and conditions on the reverse side of your order acknowledgement form and your invoice.

General notes

1. Lifting and transportation of the equipment by means of forklifts is not permitted, as this may result in serious damage of the tank bottom and the ice coils.
2. Lifting devices have been provided for short lifts and final positioning.
3. Spreader bars of the full width of the section must be used between the lifting cables to prevent damage to the section.
4. For extended lifts or where hazards exist, it is recommended to use the lifting devices in conjunction with safety slings placed under the unit.
5. As an alternative to lifting, the ice chiller thermal storage unit can be rolled into position. If rollers are used, they should be placed under the unit and must exceed the unit width.



CAUTION

When the unit is installed, all metal parts created by drilling, fastening self tapping screws, grinding, welding or other mechanical works must be removed from the unit. If they remain on the unit (typically on the double break flanges) this could lead to corrosion and eventually coating damage.

Support requirements

All units must be continuously supported by a level concrete pad designed for the unit's operating weight (see certified drawing). The pitch of the concrete pad must not exceed 2 mm per meter. Any variation over this amount must be corrected with high strength grout. Do not use shims to level the unit.

If the unit is to be rolled to its final position, the surface over which it is moved must be level and hard. Place the rollers under each corner as shown in following figures.

Recommended rigging method for 3,2 m long units

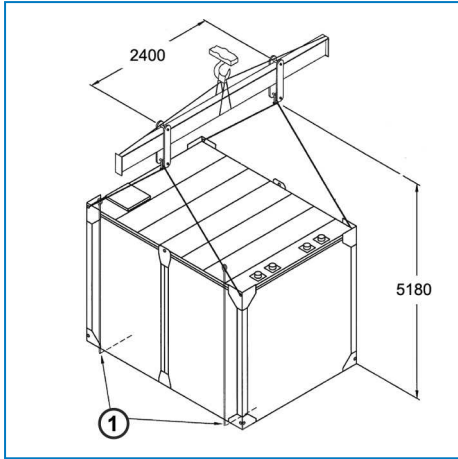

Recommended rigging method for 3,2 m long units (TSU-L184M & TSU-237M)

1. Safety slings (for extended lifts)

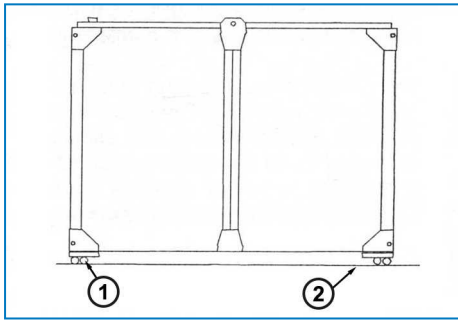

Recommended arrangement for rollers used for final positioning

1. 4 Rollers required (2 each side)
2. Floor

Recommended rigging method for 6 m long units

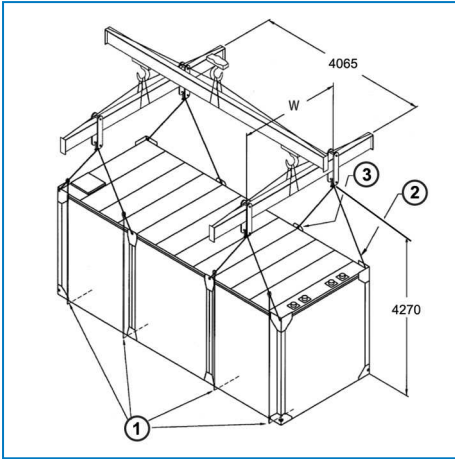

Recommended rigging method for 6 m long units

1. Safety slings (for extended lifts)
2. Lifting ear
3. Lifting cable

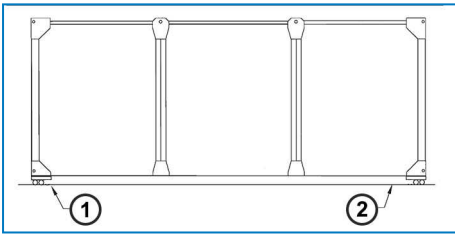

Recommended arrangement for rollers used for final positioning

1. 4 Rollers required (2 each side)
2. Floor

TANK SIZE		Width "W" (mm)
High units	Low units	
TSU-476M	TSU-L370M	2400
TSU-594M	TSU-L462M	2980
TSU-761M	TSU-L592M	3600

Dimensions for 6 m long units

System charging

Coils are filled in the factory with nitrogen. Release the nitrogen in a properly ventilated area, before charging the system with glycol. The system should be filled with an industrial grade inhibited ethylene glycol solution, typically 25% (-10°C freezing point) concentration.



CAUTION

Do not use uninhibited glycols or antifreeze solutions intended for automotive use.

The glycol solution should be premixed in a tank before being added to the system. This provides a uniform mixing and eliminates the concern of water pockets that could freeze and cause system damage. If the solution is to be mixed on site, be sure to use good quality dilution water and follow the manufacturer's directions. Mix the solution thoroughly and test the concentration before it is introduced to the system. Use a refractometer specifically designed for heat transfer solutions to determine the glycol concentration. When calculating the total volume of solution required, see table "Fluid volumes" in chapter "System charging" on the previous page, for the internal volume of the thermal storage coils. To fill the system, open all system flow control valves and the air vent(s) at the system high point(s) to allow the glycol solution to flow freely throughout the system. Then, pump the premixed solution into the system. When the charging is almost complete, isolate the charging tank or tank truck from the glycol loop and turn on the system circulating pump to ensure the solution is circulated throughout the loop. Operate the pump for 24 hours and then check the system pressure and glycol concentration.



- (1) Standard in- and outlet connections are threaded. To avoid damage to insulation and tank lining, welding at the tank connections is not recommended.
- (2) Freeze protection must be obtained by the use of ethylene or propylene glycol or other anti-freeze solutions in appropriate concentrations.
- (3) The systems lowest operating temperature should be at least 3°C to 4°C above the anti-freeze solution freeze point.
- (4) Ethylene glycol solutions are not compatible with galvanized steel parts. Therefore glycol piping should only be galvanized at the outside.
- (5) The Model TSU-237M and TSU-L184M have two ND15 vent connections (see figure below "Air vents on TSU-237M and TSU-L184M") that must be bled during the charging process. The installing contractor is responsible for providing the vent valves and plugs

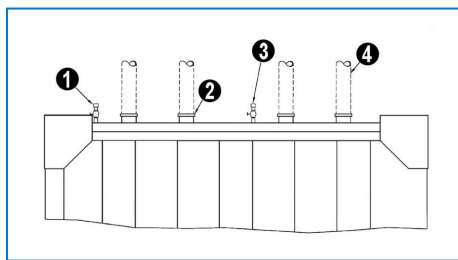

End elevation - Air vents on TSU-237M and TSU-L184M

1. Air vent (valve and cap by others)
2. Connection
3. Air vent (valve and cap by others)
4. Piping (by others)

Purge requirements

The installer of BAC equipment must ensure proper system purging of air prior to operation. Entrained air can obstruct the proper flow of glycol solution, resulting in higher operating pressures than design and reduced thermal storage capacity.



TSU-M INSPECTION PRIOR TO START-UP

General

Prior to start-up, the following services, which are described in detail in the Operating and Maintenance Manual (see table "Recommended maintenance and monitoring programme") must be performed.

Proper start-up procedures and scheduled periodic maintenance will prolong the life of the equipment and ensure trouble-free performance for which the unit is designed.

Assistance

BAC has established a specialized total care company called Balticare. The BAC Balticare offering involves all elements required to ensure a safe and efficient operation of your evaporative cooling products.

For more details, contact your local BAC representative for further information and specific assistance at www.BaltimoreAircoil.eu

More information

REFERENCE LITERATURE

- Eurovent 9-5 (6) Recommended Code of Practice to keep your Cooling System efficient and safe. Eurovent/Cecomaf, 2002, 30p.
- Guide des Bonnes Pratiques, Legionella et Tours Aéroréfrigérantes. Ministères de l'Emploi et de la Solidarité, Ministère de l'Economie des Finances et de l'Industrie, Ministère de l'Environnement, Juin 2001, 54p.
- Voorkom Legionellose. Ministerie van de Vlaamse Gemeenschap. December 2002, 77p.
- Legionnaires' Disease. The Control of Legionella Bacteria in Water Systems. Health & Safety Commission. 2000, 62p.
- Hygienische Anforderungen an raumluftechnische Anlagen. VDI 6022.

INTERESTING WEBSITES

- www.BaltimoreAircoil.eu
- www.BACservice.eu
- www.eurovent-certification.com
- www.ewgli.org
- www.ashrae.org
- www.uniclima.org
- www.aicvf.org
- www.hse.gov.uk

ORIGINAL DOCUMENTATION



This manual is originally made in English. Translations are provided for your convenience. In the event of discrepancies, the English original text shall prevail over the translation.



A series of horizontal dotted lines for writing, spanning the width of the page.



A series of horizontal dotted lines for writing, spanning the width of the page.





A series of horizontal dotted lines for writing, spanning the width of the page.

COOLING TOWERS

CLOSED CIRCUIT COOLING TOWERS

ICE THERMAL STORAGE

EVAPORATIVE CONDENSERS

HYBRID PRODUCTS

PARTS, EQUIPMENTS & SERVICES

BLUE by nature
GREEN at heart



www.BaltimoreAircoil.eu

info@BaltimoreAircoil.eu

Please refer to our website for local contact details.

Industriepark - Zone A, B-2220 Heist-op-den-Berg, Belgium

© Baltimore Aircoil International nv